

***GPR-1600 UHP QT
PPB Oxygen Analyzer***

Ensure the Quality of Ultra-High Purity Gases

Breakthrough Pico-Ion Sensor Technology
Sensitivity 0.5% FS Range, < 1 PPB Oxygen
Orbitally Welded & VCR Connections
Integral Zero & Sensor Isolation System
Fast Recovery, No Maintenance
Auto Ranging, Zero & Calibration
Communication Link USB or RS232

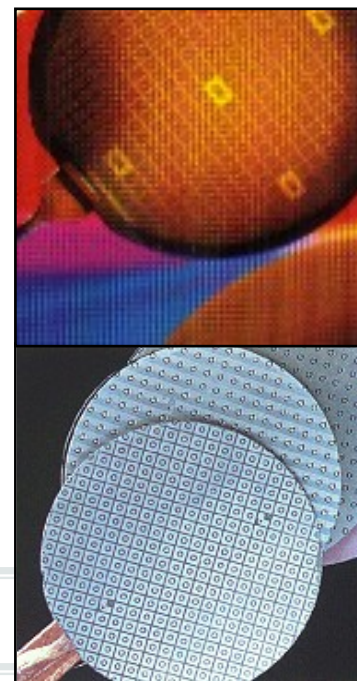

New Pico-Ion Sensor Technology

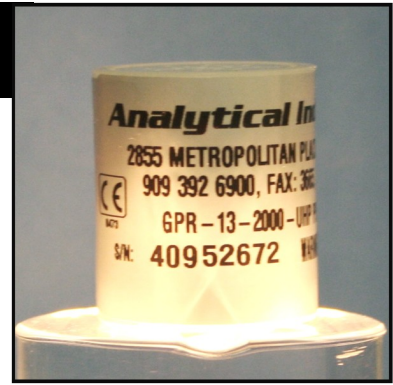

The presence of parts-per-billion levels of oxygen in semiconductor process gases such as nitrogen, argon, helium and hydrogen can adversely affect both manufacturing yields and quality. Oxygen can react with silicon during processing, forming undesirable gate oxide growth on the wafer surface that alters the characteristics of the device.

The unique features of the Pico-Ion sensor are its use of a proprietary electrode material as the sensing cathode and a unique controlled gas delivery path. Together they produce the signal output needed to obtain a lower detectable limit (LDL) of less than 1 ppb while minimizing the evaporation of water from within the sensor when exposed to extremely dry ultra high purity process gases.

The design of the gas chamber above the cathode maximizes the rate oxygen reacts at the cathode thereby minimizing the amount of oxygen that escapes unreacted and dissolves in the electrolyte.

The design also minimizes the temperature dependence of the sensor's signal at very low oxygen levels thereby ensuring the long-term stability of the sensor.

To further enhance the stability of the Pico-Ion sensor the GPR-1600UHP ppb O₂ Analyzer is equipped with a temperature controlled heater system, the capability to display temperature along with the oxygen value and allow the user to manually enter a temperature coefficient to fine tune the temperature compensation.

These characteristics produce a sensor with a nominal sensitivity of less than 1 ppb, a noise level less than 0.2 ppb, excellent stability, a 90% full scale response of less than 60 seconds and the ability to recover quickly from a process upset condition.

The sensor can be operated continuously for 18 months without any maintenance and does not require the addition of electrolyte or water.

The new Pico-Ion sensor technology enables the GPR-1600UHP QT analyzer to offer users a cost effective solution for detecting ppb level oxygen contamination in UHP process gases.

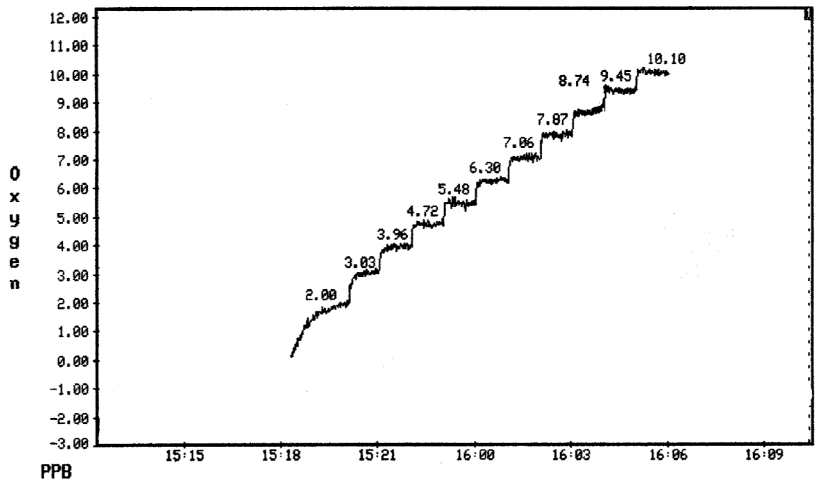

Test results illustrating the Pico-Ion sensor's response to incremental hourly 1 ppb (parts-per-billion) oxygen challenges.

GPR-1600UHP Linearity Test

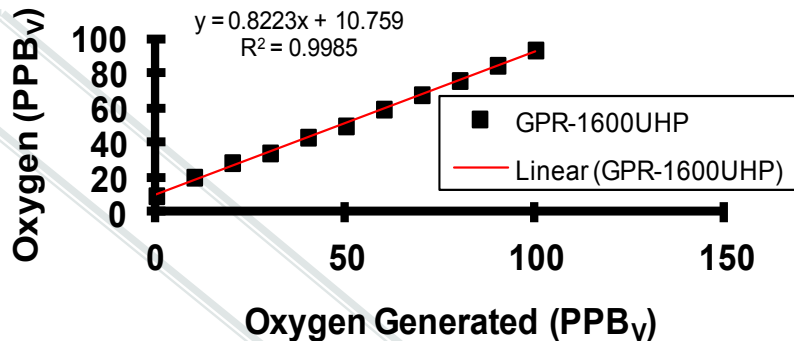

State of the Art Analyzer

Realizing the full potential of the Pico-Ion sensor and meeting the demanding requirements for detecting less than 1 ppb of oxygen contamination in ultra-high purity semiconductor process gases requires state of the art sampling system and electronic interface.

The design of the ultra-clean leak free sampling system features minimal dead volume, 316L stainless wetted parts, leak proof VCR fittings or orbitally butt welded connections and pneumatic diaphragm valves. The modular nature of the design enables the user to configure the sampling system according to specific needs. The basic unit includes sensor isolation valves and is expandable to include the selective addition of the following optional modules:

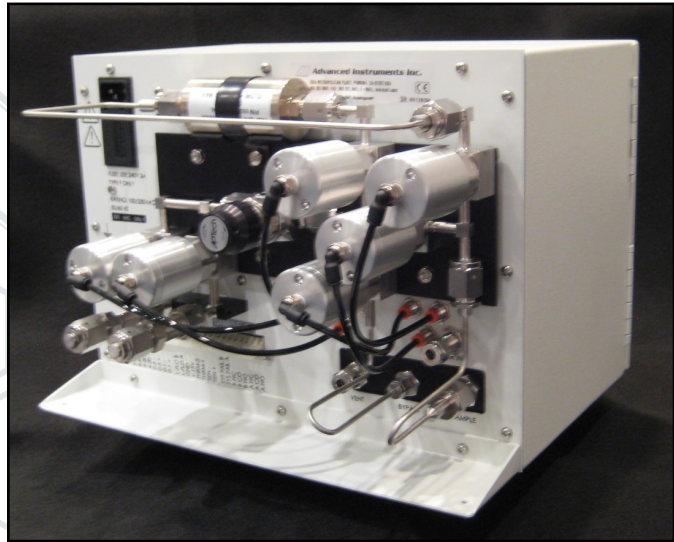

- Separate sample and span inlets
- Integral pressure regulator and flow control
- Integral zero gas generator
- Integral sample bypass for isolating the sensor from high oxygen levels during transport, start-up, process upset conditions and maintenance

An integral temperature controlled heater system further enhances the stability of the analyzer. This system includes insulating the enclosure, a PID controller and thermal runaway protection that maintain the sample and sensor at a constant temperature. As a result, signal drift is less than 1 ppb oxygen during day-and-night cycles where ambient temperatures fluctuations were typically $\pm 10^{\circ}\text{F}$.

Proprietary software that controls the analyzer is menu driven and displayed on a large graphical LCD display which the user navigates via four control keys. Using the bi-directional RS232C or USB port, the analyzer features can be accessed and operated remotely using a PC.

The GPR-1600 UHP QT provides a number of electronic features that the user can confidently employ to assure consistently reliable performance:

- Automatic control over the introduction of sample, zero and span gases
- Programmable timing for automatic zero and calibration routines
- Automatic ranging with manual override
- Automatic isolation of the sensor at programmable oxygen values
- Automatic isolation of the sensor in the event of power interruptions
- Data acquisition of a fixed number of points at programmable intervals
- Manual entry of a temperature coefficient enables the user to fine tune the temperature compensation for added stability
- Weak sensor warning, visually displayed at calibration
- Self diagnostics, two adjustable alarms with dry relay contacts and a power failure alarm

The analyzer is packaged in a compact bench top enclosure. Optional bezels are available for panel mounting the analyzer or mounting it in a 19" rack making the GPR-1600 UHP QT ideal for either dedicated on-line analysis of process gases or tracking down leaks and certifying the integrity of the piping delivery systems as part of a mobile cart.

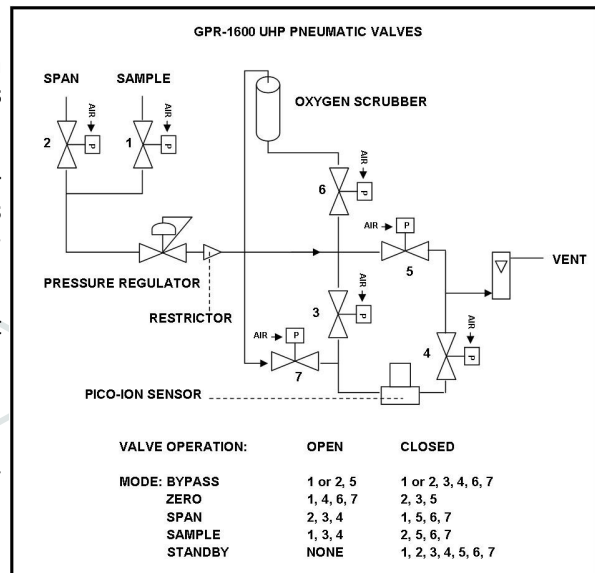



Technical Specifications *

Accuracy:	< 2% of FS range under constant conditions																
Analysis:	0-100 ppb, 0-1 ppm, 0-10, 0-100 ppm FS ranges; auto-ranging or manually lock on single range																
Application:	Analyze oxygen from 0.5 ppb to 100 ppm in ultra-high purity inert process He and H ₂																
Area Classification:	General purpose																
Alarms:	2 adjustable form C relay contacts non-latching; "weak sensor" indicator; power failure; system failure																
Calibration:	Certified gas of O ₂ balance N ₂ approximating 80% of range above analysis range recommended for optimum																
Compensation:	Barometric pressure and temperature; heated sample system and sensor housing																
Connections:	Sample and span inlets - 1/4" VCR fittings; air inlet and vent - 1/4" compression tube fittings																
Controls:	Water resistant keypad; menu driven range selection, calibration, alarm and system functions																
Data Acquisition:	Selectable data point intervals																
Display:	Graphical LCD 5 x 2.75; resolution 0.5 ppb; displays real time ambient temperature and pressure																
Enclosure:	Painted aluminum 13.9" x 9.9" x 13.4" bench top																
Flow Sensitivity:	None between 1-3 SCFH, 1 SCFH recommended																
Linearity:	> .995 over all ranges																
Pressure:	Inlet - regulate to 20-50 psig, max 150 psig; vent - atmospheric not to exceed ±5" water column																
Power:	Specify 100/120 or 220/240 VAC																
Recovery Time:	<table border="0"> <tr> <td>O₂ Level</td> <td>Duration</td> <td>O₂ Target</td> <td>Recovery on N₂</td> </tr> <tr> <td>9 ppm</td> <td>1 minute</td> <td>10 ppb</td> <td>15 minutes</td> </tr> <tr> <td>9 ppm</td> <td>1 minute</td> <td>1 ppb</td> <td>60 minutes</td> </tr> <tr> <td>1 ppm</td> <td>5 minutes</td> <td>1 ppb</td> <td>30 minutes</td> </tr> </table>	O ₂ Level	Duration	O ₂ Target	Recovery on N ₂	9 ppm	1 minute	10 ppb	15 minutes	9 ppm	1 minute	1 ppb	60 minutes	1 ppm	5 minutes	1 ppb	30 minutes
O ₂ Level	Duration	O ₂ Target	Recovery on N ₂														
9 ppm	1 minute	10 ppb	15 minutes														
9 ppm	1 minute	1 ppb	60 minutes														
1 ppm	5 minutes	1 ppb	30 minutes														
Response Time:	90% of final FS reading < 60 seconds																
Sample System:	Manual pressure regulation, flow control and indicator. Pneumatic (minimum 80 psig air supply) valves control sample and span gas inlets, bypass and isolation of sensor, and, integral zero gas system. Electro-polished tubing with orbitally welded or VCR connections.																
Sensitivity:	< 0.5% of FS range																
Sensor Model:	GPR-13-2000UHP - requires no maintenance																
Sensor Life:	15 months at 25°C and 1 atm; average O ₂ < 10 ppm																
Signal Output:	4-20mA isolated and 0-1V																
Temp. Range:	5° to 45°C																
Warranty:	12 months analyzer; 12 months sensor																
Wetted Parts:	316L stainless steel																

Optional Equipment

Bezels for panel and 19" rack mounting; wall mount NEMA4X enclosure

* Specifications subject to change without notice



GPR-1600 UHP QT PPB Oxygen Analyzer

- **Breakthrough Pico-Ion™ Sensor**
- **Sensitivity <0.5 parts-per-billion**
- **Fast Recovery from Upset Excursions**
- **Fully Automatic Menu Driven Controls**
- **Programmable Auto-Zero & Auto-Cal**
- **Remote Communication via USB**
- **Modular 316L SS Sample System with Orbitally Welded & VCR Connections**
- **Automated Pneumatic Valves**
- **Easy Access to Valves & Connections**

