

WK-Series (White Knight™) Series Gas Purifiers

Features and Benefits

- For point-of-use to bulk flow specialty gas purification
- **Highest Lifetimes**
- **Best Impurity Removal Efficiencies**
 - Removes critical contaminants to sub part-per-billion levels
- Patented built-in poppet valves at purifier inlet and outlet for purifiers filled with: OMA, OMS, OMX, OMX-Plus, and NHX-Plus
- Enhances manufacturing process economy and improves equipment performance
- Provides consistently high purity gas under fluctuating inlet impurity conditions
- Improves component lifetime and reduces particle generation by removing moisture from corrosive gases
- Compact Footprint; Inline design
- Easy to install & operate
- No heating or cooling required
- Quick start up
- All metal parts, Type 316L stainless steel, or Nickel 200
- Mounting bracket for WK-9000F
- Refills available for most gases (except or corrosive gases)
- Economical, Low Cost of Ownership

Specifications

- 0.003 µm filter with 99.999999% retention (PTFE or 316L SS)
- Internal surface finish < 15 µin R_a
- Maximum operating temperature is 70°C

Connections

- Male inlet and outlet connections, 1/4" VCR - compatible

Options

- Inlet and outlet isolation valves (standard for WK-9000F)

Purifier Models

Model No.	Maximum Recommended Flow Rate*	Maximum Allowable Working Pressure
WK-75F	5 slpm (0.3 NM ³ /hr)	1,000 psig (7 Mpa)
WK-500F	60 slpm (3.6 NM ³ /hr)	500 psig (3.5 Mpa)
WK-2500F	300 slpm (18 NM ³ /hr)	500 psig (3.5 Mpa)
WK-9000F	1000 slpm (60 NM ³ /hr)	350 psig (2.5 Mpa)

* Applies to designs without built-in poppet valves.

Overview

NANO-CHEM® WK-Series (White Knight™) purifiers offer the highest lifetimes and the best impurity removal efficiencies in a very economical design. The in-line design enables a very compact footprint and allows drop-in replacement of competing hardware designs. WK-Series are available in a number of sizes ranging from 55-ml for point-of-use applications to 9-liters for bulk gas purification. Flow rates range from 3 slpm (0.2 NM³/hr) to 1000 slpm (60 NM³/hr).



Gas Type	Impurities Removed
Nitrogen (N ₂), Argon (Ar), other inerts	< 100 ppt H ₂ O, O ₂ , CO ₂ LDL < 1 ppb CO* < 100 ppt NMHC (with OMX-Plus™) LDL NO _x , SO _x , H ₂ S
Ammonia (NH ₃)	< 100 ppt H ₂ O, O ₂ , CO ₂ in inert gas LDL < 1 ppb CO* < 45 ppb H ₂ O in ammonia LDL NH ₃ -CO ₂ complexes, SiH ₄ , Siloxanes, GeH ₄ , H ₂ S
Silane (SiH ₄)	< 100 ppt H ₂ O, O ₂ , CO ₂ LDL < 1 ppb CO* Chlorosilanes, disilane, siloxanes, arsine, phosphine
Hydrogen (H ₂), Methane (CH ₄), Ethane (C ₂ H ₆), other HC	< 100 ppt H ₂ O, O ₂ , CO ₂ LDL < 1 ppb CO* NO _x , SO _x , H ₂ S
Sulfur Hexafluoride (SF ₆), Carbon Tetrafluoride (CF ₄), other fluorocarbons	< 100 ppt H ₂ O, O ₂ , CO ₂ in inert gas LDL < 10 ppb O ₂ , H ₂ O in sulfur hexafluoride LDL
Oxygen (O ₂), Carbon Dioxide (CO ₂), Nitrous Oxide (N ₂ O)	< 10 ppb H ₂ O
Carbon Monoxide (CO)	Metal Carbonyls: Fe, Ni
Corrosives (HCl, HBr, Cl ₂ , SiH ₂ Cl ₂ , SiHCl ₃ , BCl ₃)	< 1 ppb H ₂ O in inert gas < 100 ppb H ₂ O in HBr LDL < 150 ppb H ₂ O in HCl Volatile Metals: Fe, Mo, Cr, Ni, Mn, Ti

LDL – Lower Detection Limit by State-of-the-Art Analytical Instrumentation

NMHC – Non-methane Hydrocarbons

*NOTE: CO is removed efficiently by OMX & OMX-Plus™ media at low flow rates (recommend 1/10 of normal flow rate)

For a detailed list of purification media and impurities removed, refer to the Purification Media Table in Nanochem® Purification Solutions Brochure.



MATHESON

ask... The Gas Professionals™

Pressure Drop

NANOCHEM® Purifier Model WK-75F-NP

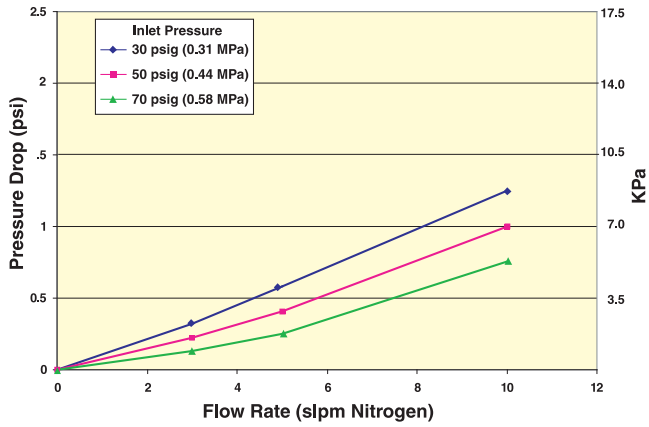

NANOCHEM® Purifier Model WK-2500F-NP

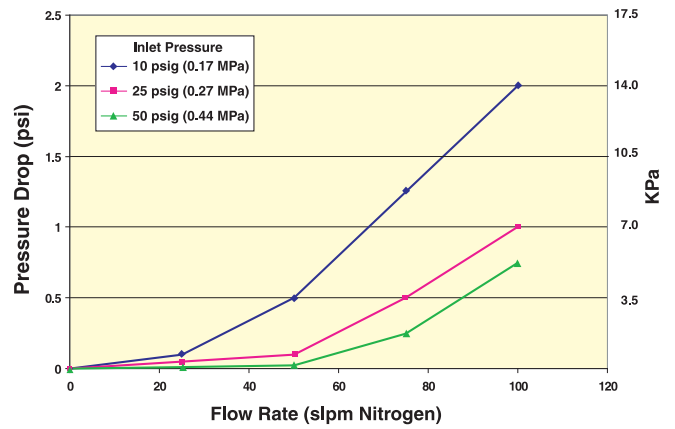

Dimensions

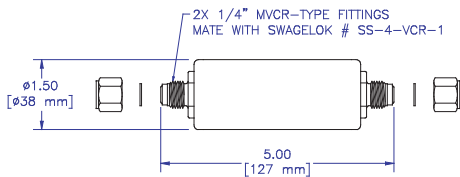

NANOCHEM® Purifier Model WK-75F

**actual media volume is 55 ml*

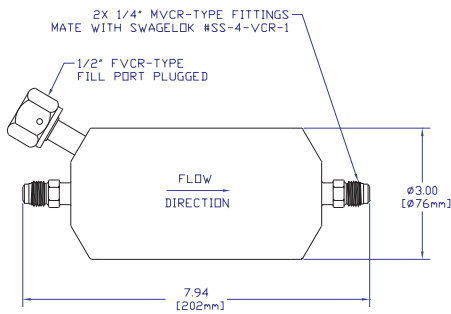

NANOCHEM® Purifier Model WK-500F

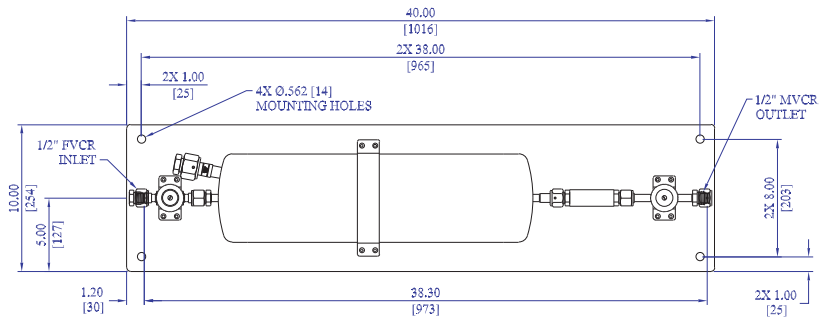

NANOCHEM® Purifier Model WK-9000F

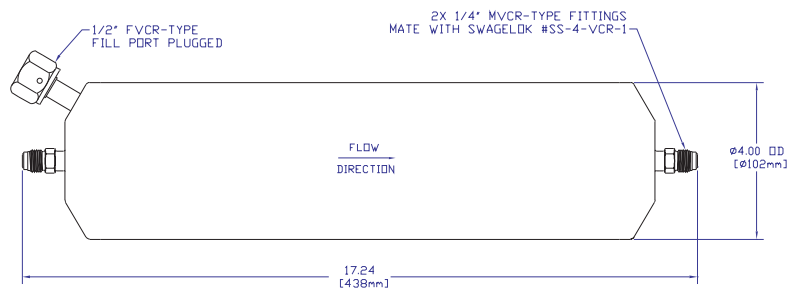
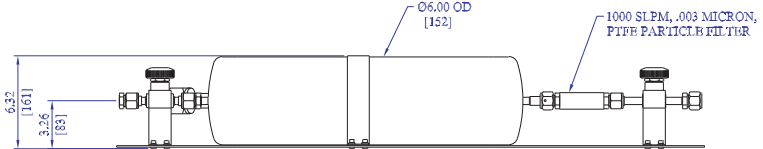

NANOCHEM® Purifier Model WK-2500F

Dimensions in inches (mm)

Note: Purifiers are shown in horizontal position for illustration purposes only. A vertically-oriented installation is preferred.

Models WK-75F, WK-500F and WK-2500F have a 0.003 µm particle filter.

Equipment Technology Center

166 Keystone Drive
Montgomeryville, PA 18936
Tel: 800-828-4313 • Fax: 215-619-0458
Email: Info@mathesongas.com

Specifications are subject to change. Please check www.mathesongas.com for most current information.

White Knight is a trademark of Matheson Tri-Gas, Inc.
NANOCHEM is a registered trademark of Matheson Tri-Gas, Inc.
VCR is a registered trademark of Swagelok Company
Printed in USA PB037 R09/11



MATHESON

ask...The Gas Professionals™